



## Bird Bracket Chain Template Instructions

The Bird Bracket Chain is great for quick and easy block and border designs.



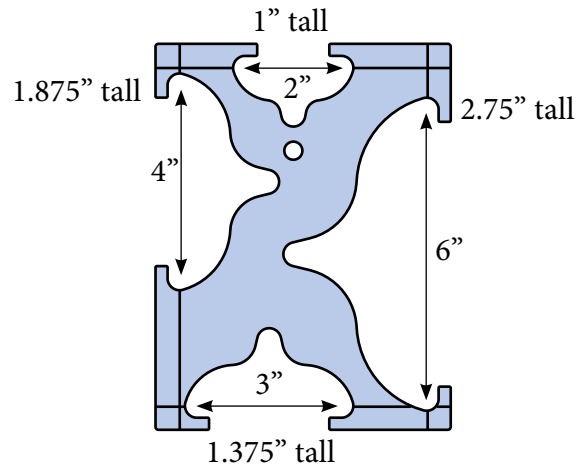

Overall size: 6" x 8"

MQT-BBC  
1/4" thick

HMQT-BBC  
3/16" thick



If you are using the template(s) to quilt around (such as a long/mid-arm machine or high shank home machine), you must use 1/4" acrylic thickness. If you are on a low shank home machine, you must use 3/16" acrylic thickness. If you are on a machine that is stationary, you may find it helpful to put some type of agent such as Grip Stop Dots or spray adhesive on the templates. Before using, peel any film/paper masking from the templates so you can see through the clear plastic.

SYMBOL GUIDE	
	ruler foot
	start
	stop and needle down
	back stitching

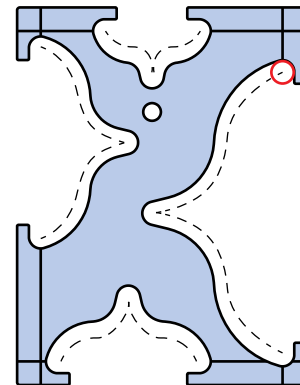

Note:

- 1) When using the template(s) to quilt around you must have a round, thick foot on your machine as well as a base (such as an extend-a-base or ruler base).
- 2) When using the template(s) to quilt around you will be stitching 1/2" larger (the width of your foot) or 1/4" wider if only using a portion of the template (the distance from your needle to the outer edge of your foot).
- 3) You may need to start with drawn/chalked guidelines or seam lines on your quilt.

## CREATE A SWAG BORDER

Use the etched lines in the tool to align your chosen opening over the seam or line. Place the left-hand side of the opening on the foot. Stitch from one end of the opening to the other. Needle down.

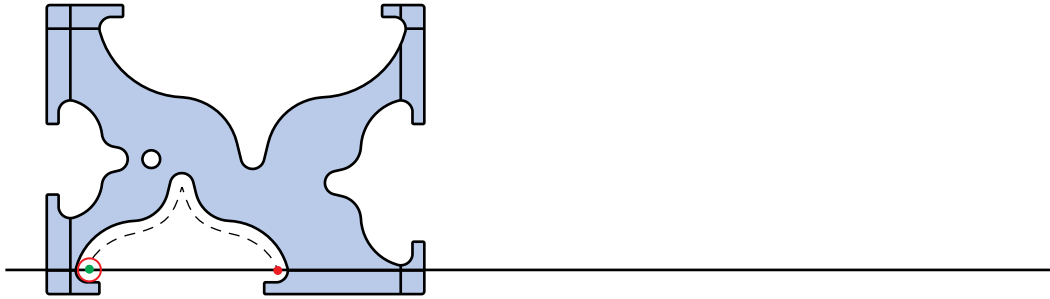

Slide the tool to the right to return to the starting point and repeat to desired length. Needle down.

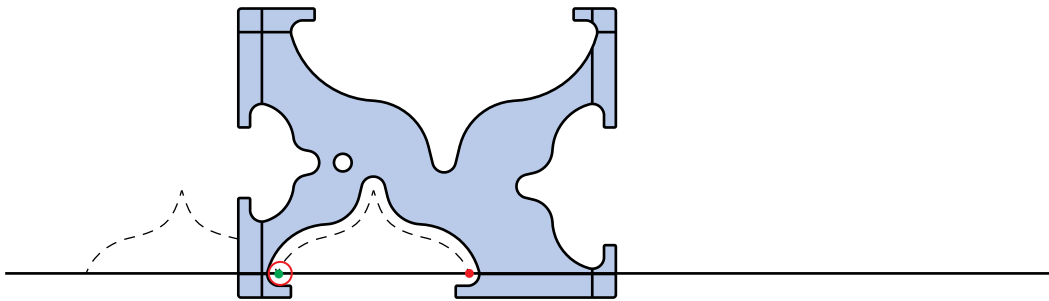

Completed 1st row.

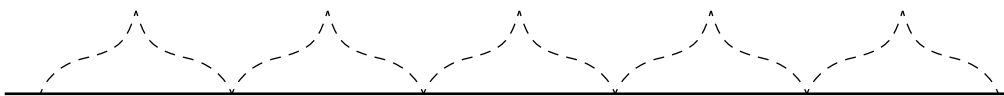

Rotate the template 180° and align the base of the template to the guideline and stitch in the reverse direction. Move tool to the left and continue to the end of your row.

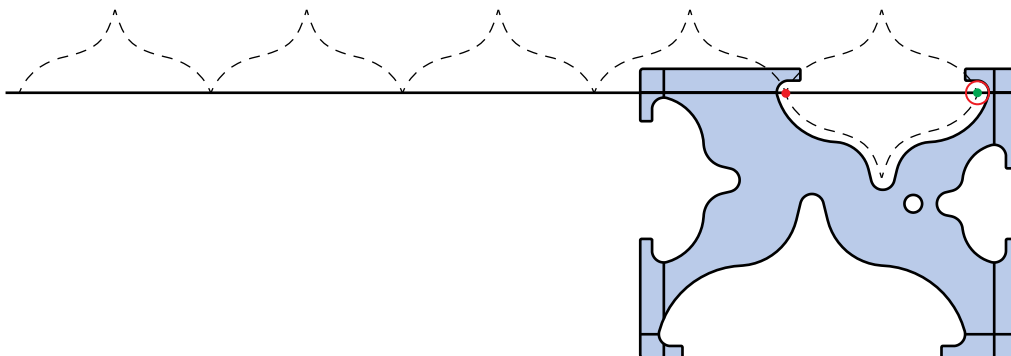

Completed design.

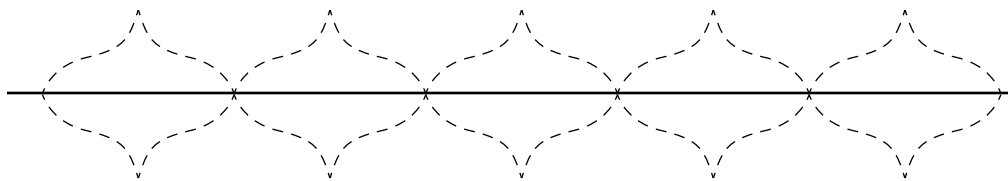

### VARIATIONS

Create a row of stitches on top of the line or below, or combine both for many variations.

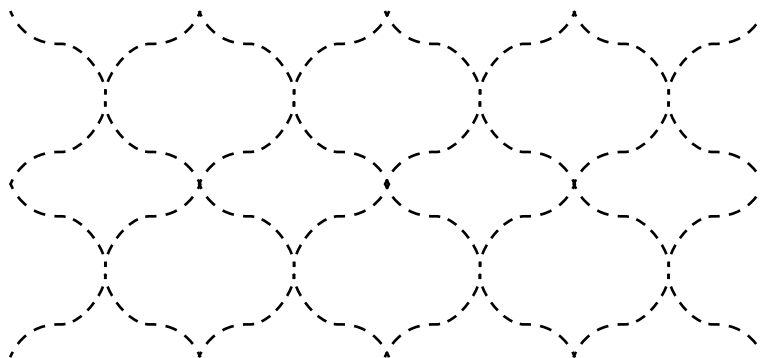
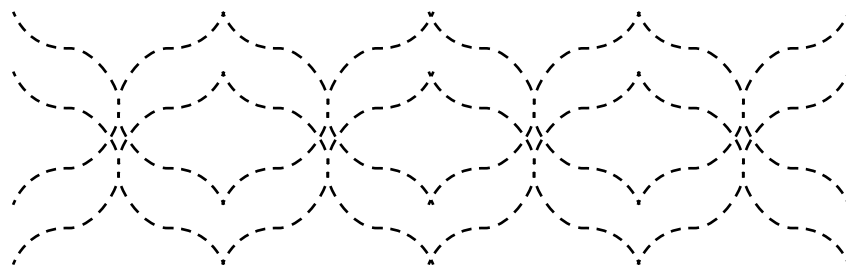

## BLOCK DESIGN

Choose the opening size that you want. Align the etched lines on the template to one of the seamlines on your block. Stitch from start to stop. Needle down. Turn the template 90°. Fit template to your ruler foot and align to your seamline. Stitch from start to stop. Use the illustrations below as your guide.

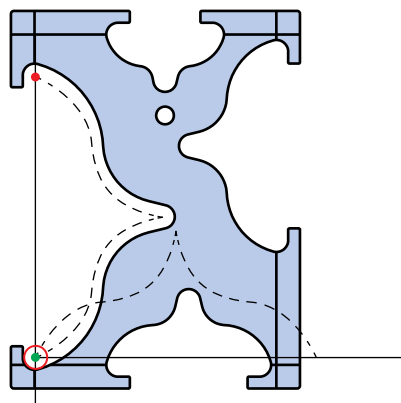
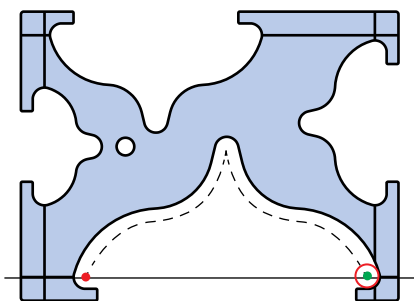

Continue stitching around the 4 sides of the square. Repeat for the desired design. Follow the red arrows for the suggested continuous stitching path such as the 9-patch design below.

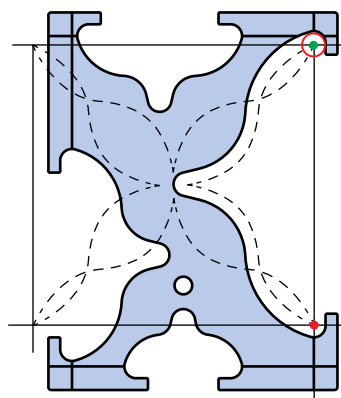
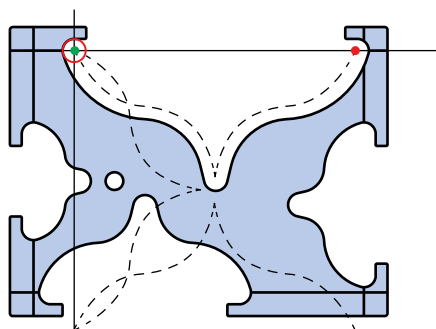

Completed single block design.

